

*A. Kelsey,*

*Turning Regular Forms.*

*N<sup>o</sup> 51,388.*

*Patented Dec. 5, 1865.*

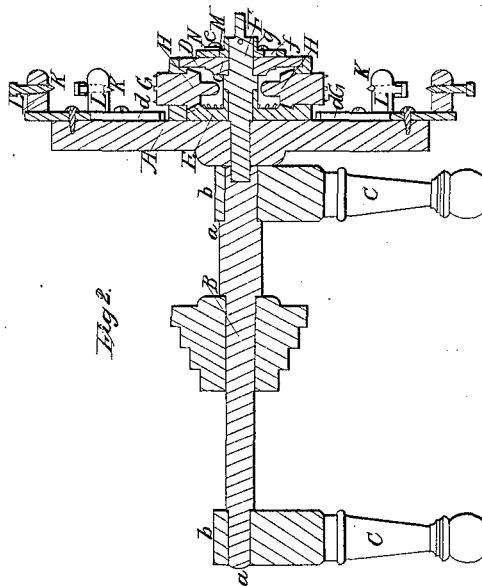
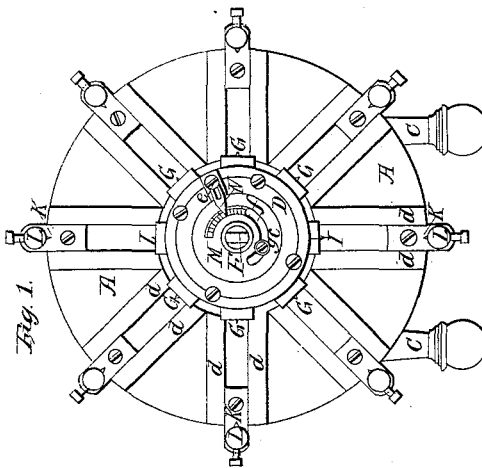
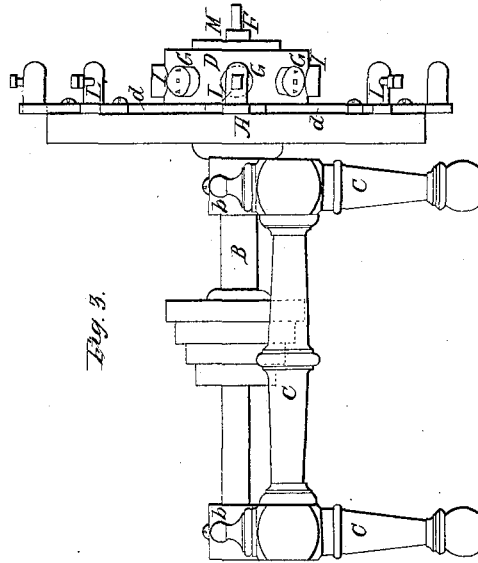
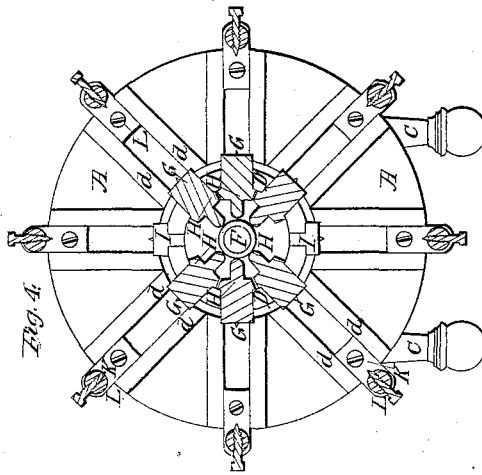

*Witnesses:*  
*Thos. Curtis*  
*G. F. Washburn.*

*Inventor:*  
*Alex. Kelsey*  
*by his atty*  
*R. H. Enay.*

# UNITED STATES PATENT OFFICE.

ALBERT KELSEY, OF CHARLESTOWN, MASSACHUSETTS, ASSIGNOR TO HIMSELF AND AMOS BROWN, OF SAME PLACE.

## IMPROVEMENT IN PRISM-LATHES.

Specification forming part of Letters Patent No. 51,388, dated December 5, 1865.

*To all whom it may concern:*

Be it known that I, ALBERT KELSEY, of Charlestown, in the county of Middlesex and State of Massachusetts, have invented a new and useful or Improved Prism-Lathe; and I do hereby declare the same to be fully described in the following specification, and represented in the accompanying drawings, of which—

Figure 1 is a front end view, Fig. 2 a side elevation, and Fig. 3 a longitudinal section, of it. Fig. 4 is a section taken through the axes of the auxiliary mandrels and the pattern-holders.

The purpose of the said lathe is to enable a person to turn a regular prism or an article polygonal in its transverse section but varying in form in longitudinal section.

In some respects the lathe may be supposed to be analogous to that described in the United States Patent No. 10,783, granted April 18, 1854. While with my lathe regular prisms with plane faces may be turned, the said patented lathe makes all its articles with curved and not plane faces, and consequently it is incapable of producing regular prisms having plane faces or sides.

In the drawings, A denotes a large circular disk or wheel applied to one end of a driving-shaft, B, having its journals *a a* suitably supported in boxes *b b*, upheld by a frame, C.

A short tube or cylindrical case, D, projects from the outer face of the disk or plate A, and is arranged concentrically with such plate. Within this case is a bevel-gear, E, fixed to a key-shaft, F, which projects from the head *c* of the case.

Extending radially through the rim of the case, and having bearings therein, is a series of rotary mandrels, G G G, each of which carries a bevel-pinion, H, which engages with the gear E. Besides these mandrels there are two or any other suitable number of spur-heads, I I, projecting from the outer surface of the rim of the case.

Each mandrel, as well as each of the spur-heads, is provided with an adjustable center, K, whose puppet-head or carrier L slides radially on the face of the disk A and between parallel guides *d d*, projecting from such face and arranged thereon, as represented, the several carriers being provided with means of ad-

justing and fixing them at different distances from their respective mandrels or spur-heads.

A circular gage-plate, M, fastened on the key-shaft, and having on its surface suitable devices or scales, operates with an adjustable indicator, N, fixed on the case D by a clamp-screw, *e*. There is a curved slot, *f*, made through the plate M, and to receive a clamp-screw, *g*, which goes through the slot and is screwed into the head or cap-plate C, of the case D. By turning the gage M more or less we can effect the rotation of all the mandrels to the degree required.

When a stick or piece of wood is inserted between and held in place by each mandrel and its centre, and a pattern is placed between and held by each stationary spur-head and its center, the machine will be ready for use; and while the disk D is put in rapid revolution a workman, by the means of a chisel or turning-tool, duly supported on a rest, can turn down each piece of wood to the form or gage of the pattern, after which he should move the gage-plate M, so as to set the pieces of wood in a proper manner to enable him to turn from them the necessary amount to produce another face on each of them. In this way he is to continue until each piece may be reduced to a regular prism or is polygonal in any transverse section taken through it.

I do not claim the lathe as represented in the United States Patent No. 10,783.

I claim as of my invention—

1. My improved prism-lathe, made substantially as hereinbefore described—viz., with its mandrels and spur-heads G I, and their centers K, and the poppet-heads I thereof, arranged on the face of the head or wheel A, and in other respects in manner and so as to operate as set forth.

2. The combination of the gage-plate M, and its clamp-screw *g*, and indicator N, with the case D, the key-shaft F, the mandrels G, and their operating gears E, H, as described, the whole being arranged with respect to a rotary plate or wheel, D, and to operate substantially in manner and for the purpose as specified.

ALBERT KELSEY.

Witnesses:

R. H. EDDY,  
F. P. HALE, Jr.